

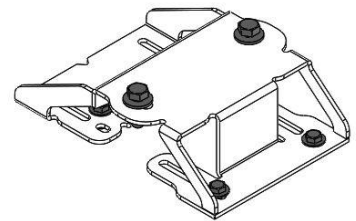

JL JEEP COMPRESSOR BRACKET

INSTALLATION GUIDE

3550220

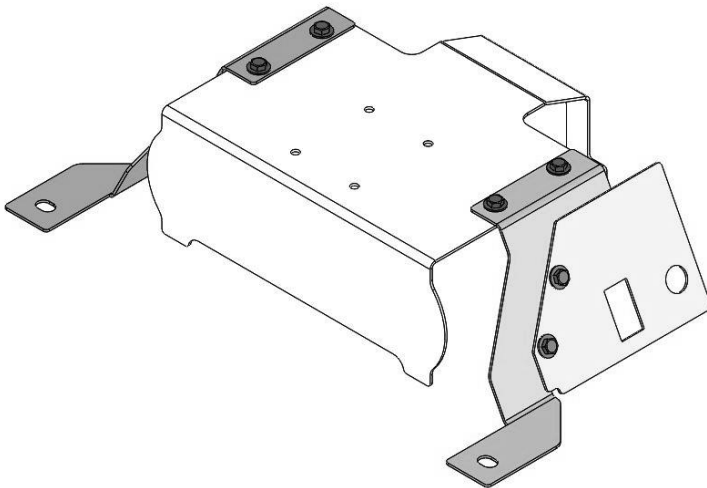

No liability is assumed for damages resulting in the use of the information contained herein. ARB Air Locker Air Operated Locking Differentials, ARB Air Locker Air Activation System and Air Locker are trademarks of ARB Corporation Limited. Other product names used herein are for identification purposes only and may be trademarks of their respective owners.



ARB 4x4 ACCESSORIES

Corporate Head Office

42-44 Garden St
Kilsyth, Victoria
AUSTRALIA
3137

Tel: +61 (3) 9761 6622
Fax: +61 (3) 9761 6807

Australian enquiries
North and South American enquiries
Other international enquiries

sales@arb.com.au
sales@arbusa.com
exports@arb.com.au

www.arb.com.au

Table of Contents

<i>INSTALLATION GUIDE</i>	1
ARB 4x4 ACCESSORIES	2
1 INTRODUCTION	4
1.1 Pre-Installation Preparation.....	4
1.2 Description.....	4
1.3 Kit Contents.....	4
1.4 Tool-Kit Recommendations.....	5
1.4.1 Tools.....	5
1.4.2 Supplies.....	5
1.5 Vehicle Preparation.....	6
2 Configuring the CKMTA12/24 Compressor	9
2.1 Orientating the compressor outlet for best fit.....	9
3 Assembly of Compressor to Main Bracket	12
3.1 Assembly of CKMTA12/24 to Main Bracket.....	12
3.2 Assembly of Switch and Quick Connect Coupling Plate.....	14
3.3 Configuration of the Air Locker Manifold kit.....	15
4 Installation of Compressor Bracket Assembly	16
4.1 Installation of Compressor Bracket Assembly.....	16
5 Installation of Air Tank	23
5.1 Installation of Air Tank.....	23
5.2 Connecting Hoses.....	26
6 Completing Installation	28
6.1 Seat Installation.....	29
6.1 Post-Installation Check List.....	29

1 Introduction

IMPORTANT:

To assure the highest level of planning and reliability goes into this installation, please read this guide in its entirety before attempting any modifications to the vehicle.

1.1 Pre-Installation Preparation

Although your *ARB Air Compressor Bracket* comes complete with all the step by step instructions you will need to install it, ARB recommends that you have your ARB Air Compressor installed by a trained professional. Many ARB distributors around the world have been fully instructed in *Air Compressor* installations by ARB, and have gained a wealth of experience and skill from years of performing similar installations.

Make sure your *Air Compressor Bracket* kit is the correct model for your application and that it contains all of the parts listed in section 1.3 below. Also, be sure you have appropriately equipped yourself with all the necessary tools, parts, materials and knowledge to complete this installation and minimize vehicle down time (see section 1.4 *Tool-Kit Recommendations*).

Please refer to your ARB Compressor and Air Locker Operating & Service Manuals for information on operating, servicing, driving technique, or trouble shooting your ARB Air Locker(s) if installed.

HINT: Place a mark inside each of the symbols as you complete each step. It is very important NOT to miss any of the steps!

1.2 Description

The JL Jeep Compressor Bracket enables the installation of a CKSA, CKMA or CKMTA with optional Air Locker Solenoids, 4L Air Tank, Quick Connect Coupling, Switch, Manifold Kit (CKMTA only) and ARB LINX PRV under the driver or passenger seat of 2 and 4 door models.

1.3 Kit Contents

- 1 X 3752380 BRACKET COMPRESSOR MOUNT
- 1 X 3752382 BRACKET TANK MOUNT
- 1 X 3752381R BRACKET FOOT MOUNT RH
- 1 X 3752381L BRACKET FOOT MOUNT LH
- 1 X 6177375 F/KIT 3550220 BRKT
 - 16 X 4584327 WASHER FLAT M6x16x1.2
 - 6 X 6151402 BOLT HXHD M6x1.0x16
 - 6 X 6151223 NUT HEX NYLOC M6x1.0
 - 1 X 6151262 BOLT HXHD M8x1.25x20
 - 2 X 6151546 BOLT HXHD M8x1.25x25
 - 1 X 4584324 WASHER FLAT M8X16.6X1.2
 - 2 X 4581307 WASHER FLAT M8X20X2
 - 1 X 3789934 F/INST 3550220 BRKT (*THIS DOCUMENT*)
 - 1 X 6151235 NUT FLANGE M8X1.25
 - 1 X 3195205 PLATE SWITCH
 - 2 X 6151526 NUT CAGED M6 1.8-2.7
 - 2 X 6151596 P CLIP 19MM

1 Introduction

1.4 Tool-Kit Recommendations

Below is a list of tools and supplies recommended to complete this installation.

1.4.1 Tools

- Standard automotive sizes of sockets including; 10mm,13mm
- T50 Torx Driver
- 8.5mm drill bit
- Electric or cordless drill.
- Combination ring/open ratchet wrenches; 10mm x2 (for compressor mount screws/nuts), 12mm (for Air line Elbows if installed), 14mm x2 (for hose connections)
- Ratchet & short extension
- Alan keys; 3mm (CKSA), 4mm (CKMA & CKMTA), for adjusting compressor body mount.
- Screwdrivers; No.2 Phillips & Small flat
- Torque Wrench 5 to 100Nm range
- A razor knife to cut the carpet (if fitting Air Locker lines through the OE plug in the floor)
- A leak test gauge (i.e., ARB# ALTG01).
- A multimeter
- A soldering iron.

1.4.2 Supplies

- Thread lubricant/sealant compound for pressure fittings (e.g., LOCTITE #567 Teflon paste or plumbing supply Teflon tape)
- A soap and water mixture to test for air leaks.
- Electrical tape.
- Teflon Tape
- Solder and/or automotive crimp fittings.
- Silicon sealant (to seal area around Air Locker lines if installed)

1 Introduction

1.5 Vehicle Preparation

A manufacturer's service manual and optional ARB operation & Installation manuals should be used in conjunction with these instructions.

- Using a T50 Torx driver remove the 4 fasteners securing the seat passenger seat to the floor.
- Tilt seat towards rear of vehicle and unplug the 2 electrical connections under the seat.
- Remove seat from vehicle.
- Unbutton carpet to expose and fold towards front of vehicle to expose HVAC duct.
- Cut HVAC duct 200mm back from OE discharge point as shown below. Disregard removed section

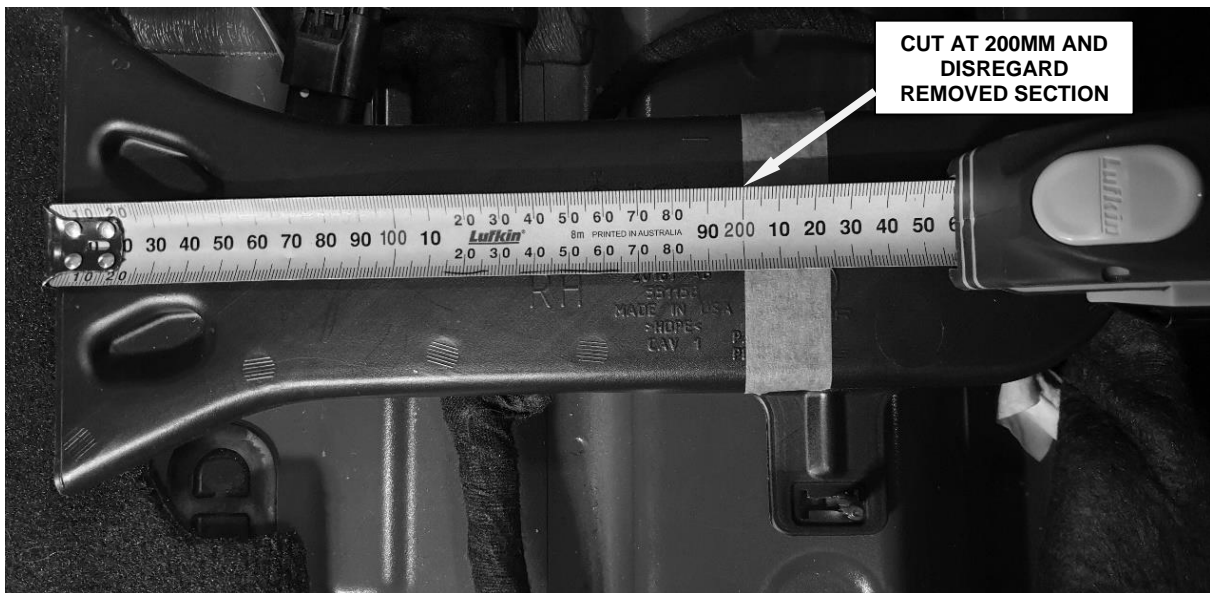

1 Introduction

- Trim carpet under the seat using the details below.
Use **Figure1** dimensions if fitting compressor bracket under **RIGHT HAND** seat
Use **Figure2** dimensions if fitting compressor bracket under **LEFT HAND** seat

FIGURE 1:

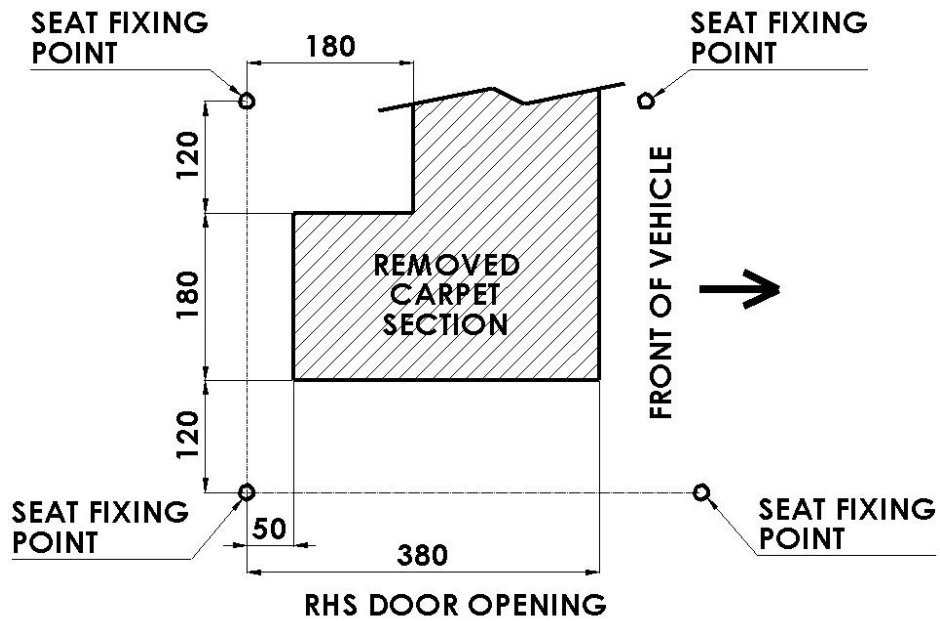

NOTE: ALL DIMENSIONS ARE IN MILLIMETERS

FIGURE 2:

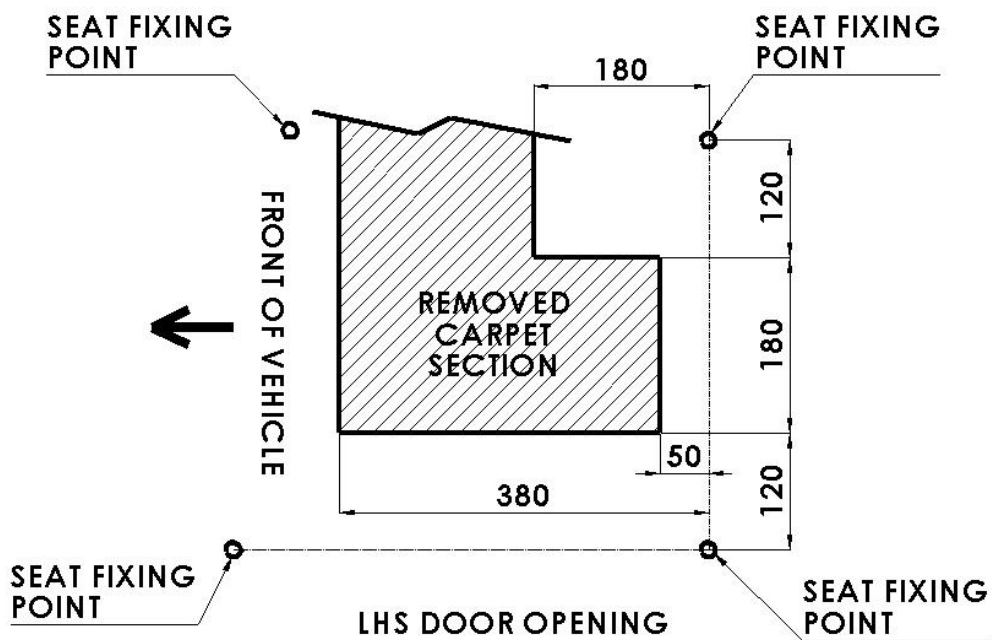

NOTE: ALL DIMENSIONS ARE IN MILLIMETERS

1 Introduction

Image below shows completed carpet trimming under RIGHT hand seat.

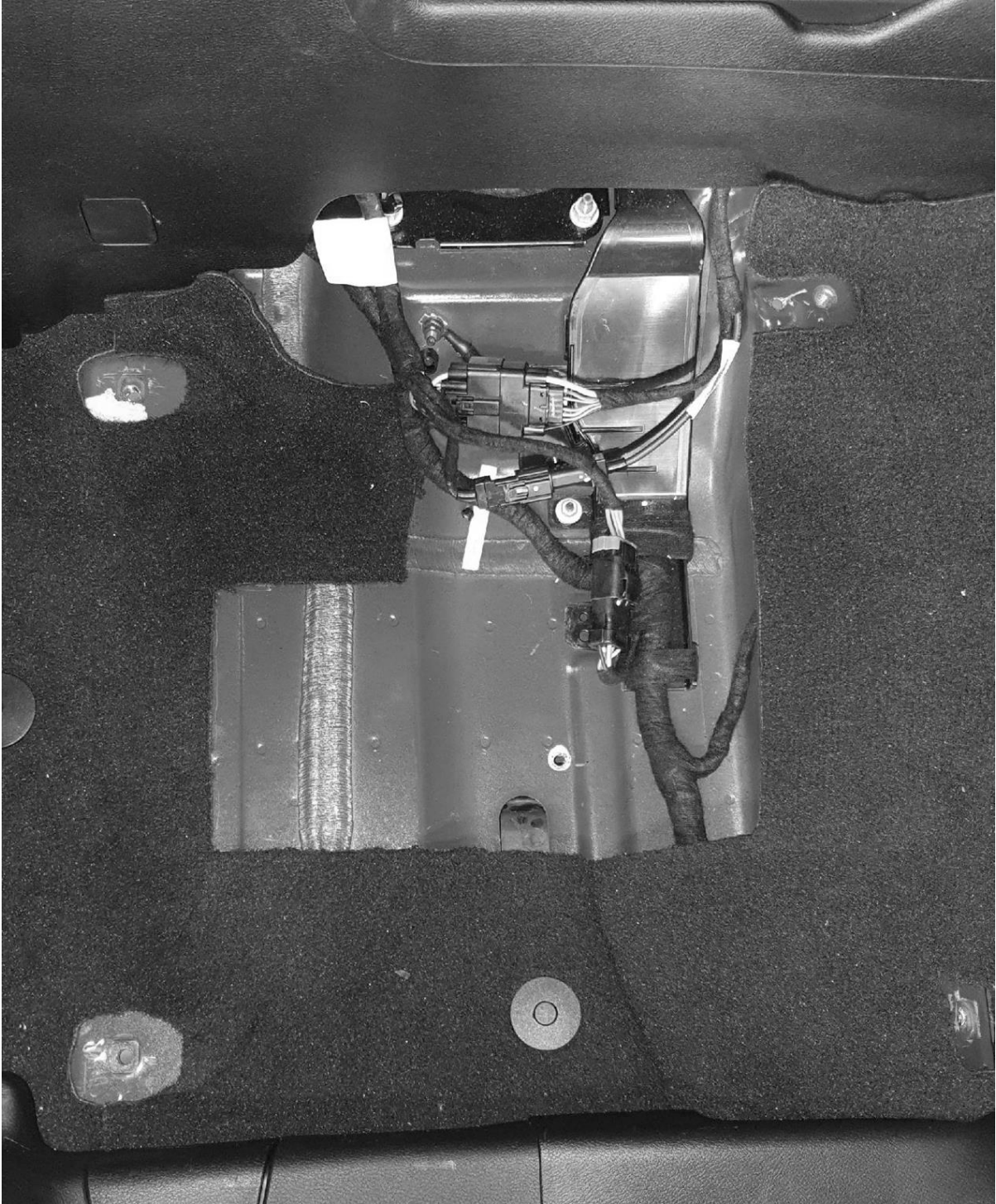

2 Configuring the CKMTA12/24 Compressor

2.1 Orientating the compressor outlet for best fit

- Refer to Section 2 of the installation guide (Part No 2102MTA12) supplied with the compressor for instructions on cover removal
- Remove manifold bolt (10mm socket)

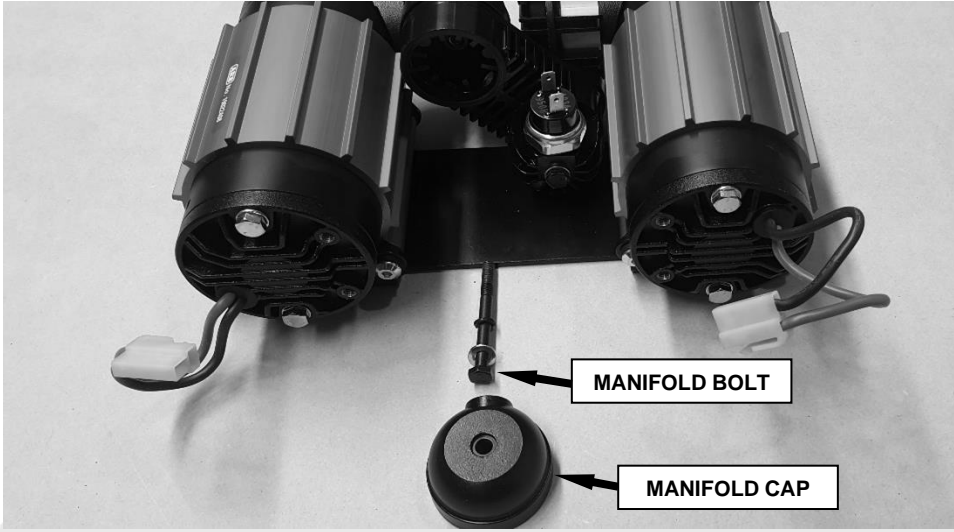

- Install 0740101 Adaptor JIC-4(M) to 1/4 NPT (M) to manifold cap and seal thread as shown (use 14mm spanner).



- Install 0740104 90 Deg Elbow JIC-4(F) to JIC-4(M)



2 Configuring the CKMTA12/24 Compressor

- Install 0740201 Hose Reinforced JIC-04 0.3M as shown. Tighten Elbow and hose fittings ensuring hose is 90deg to manifold cap as shown using 14mm spanner and 12mm spanner to retain elbow.

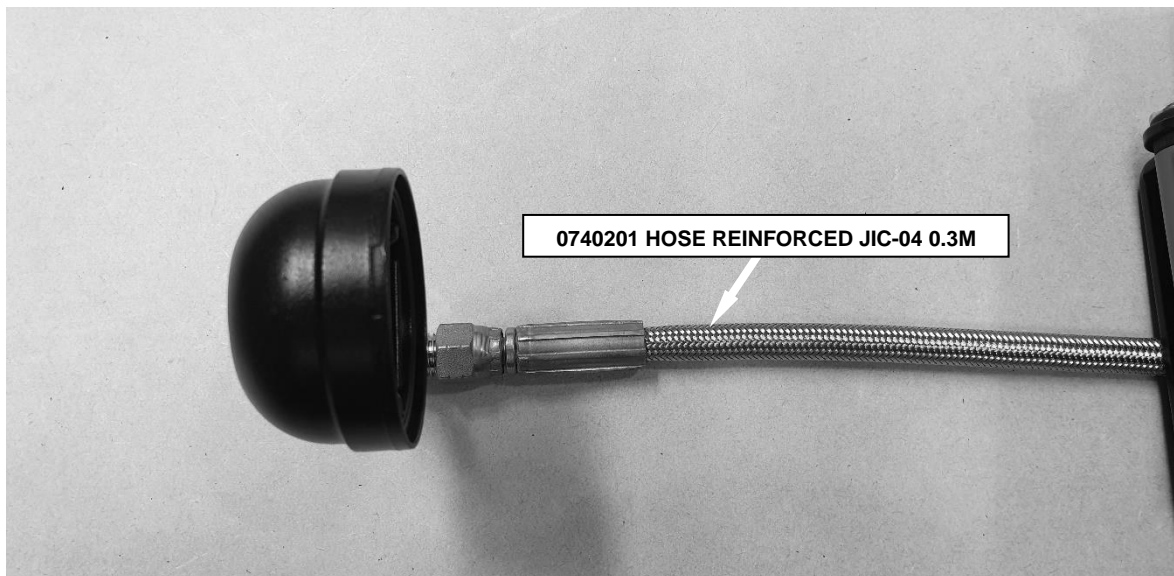

- Pass assembled hose and manifold cap through compressor assembly as shown. Reattach manifold cap to compressor and tighten manifold bolt (10mm socket) to approximately 9Nm (7 lbf.ft)

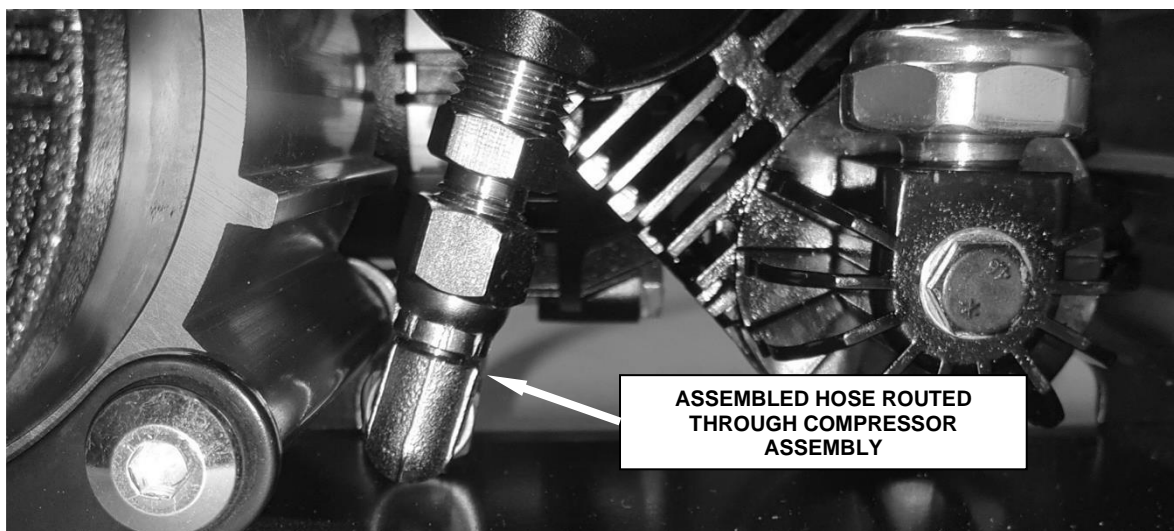
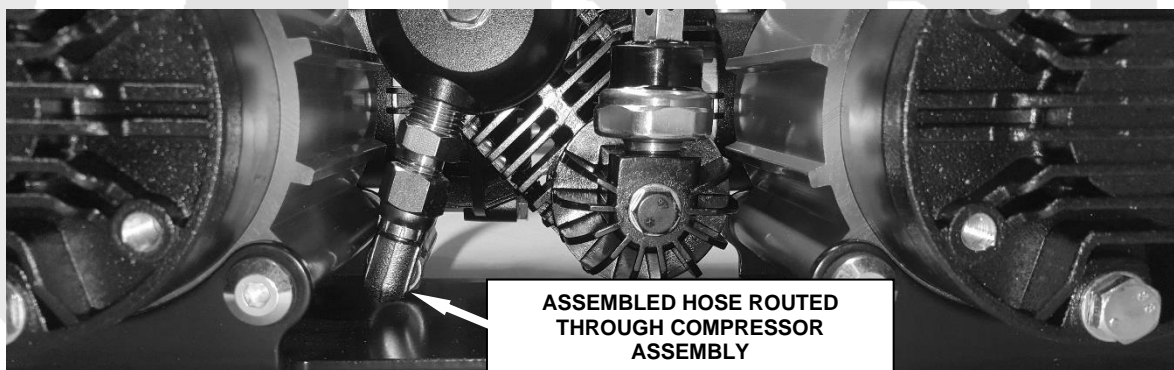

2 Configuring the CKMTA12/24 Compressor

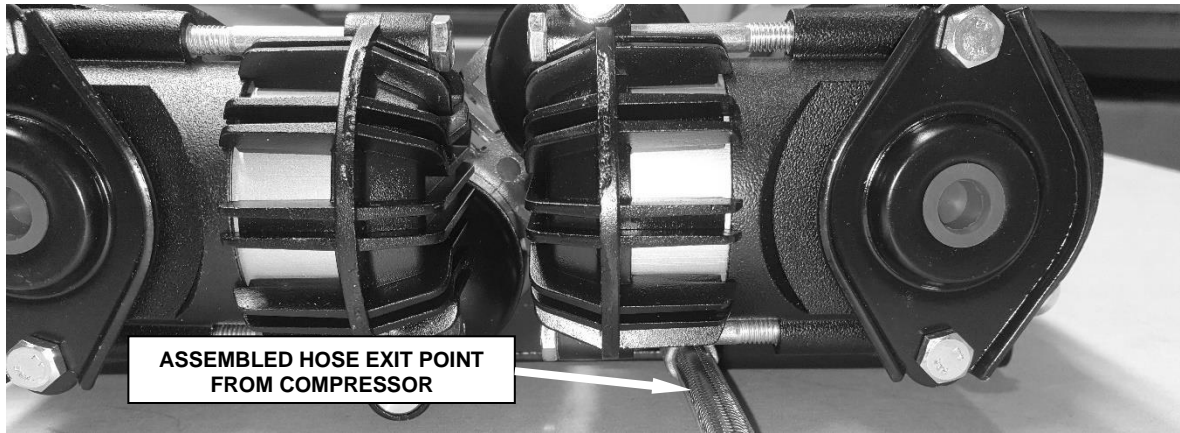

- Refit the cover reversing the operations used to remove.
- Re tighten the four cover bolts (10mm socket) to 6Nm [4.4 lbf.ft]



3 Assembly of Compressor to Main Bracket

3.1 Assembly of CKMTA12/24 to Main Bracket

Image below shows the layout of the 4 brackets which make up the compressor bracket kit.

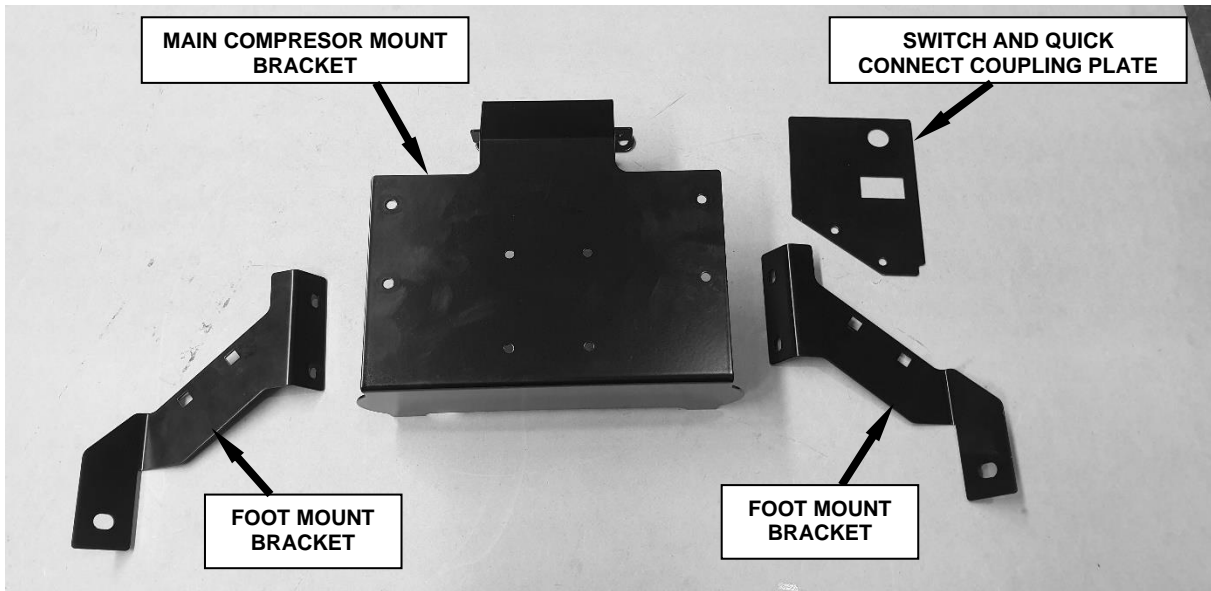

- Sit compressor on flat surface with mount face upwards.
- Place the main compressor mount bracket and the two, foot mount brackets on compressor mount face as shown. Fasten using 4 of the fasteners that came with the CKMTA12/24 compressor plus 4 X Flat Washers (M6 X16X1.2) supplied with the compressor bracket kit.
- Torque M6 fasteners to 9Nm [7lbf.ft]

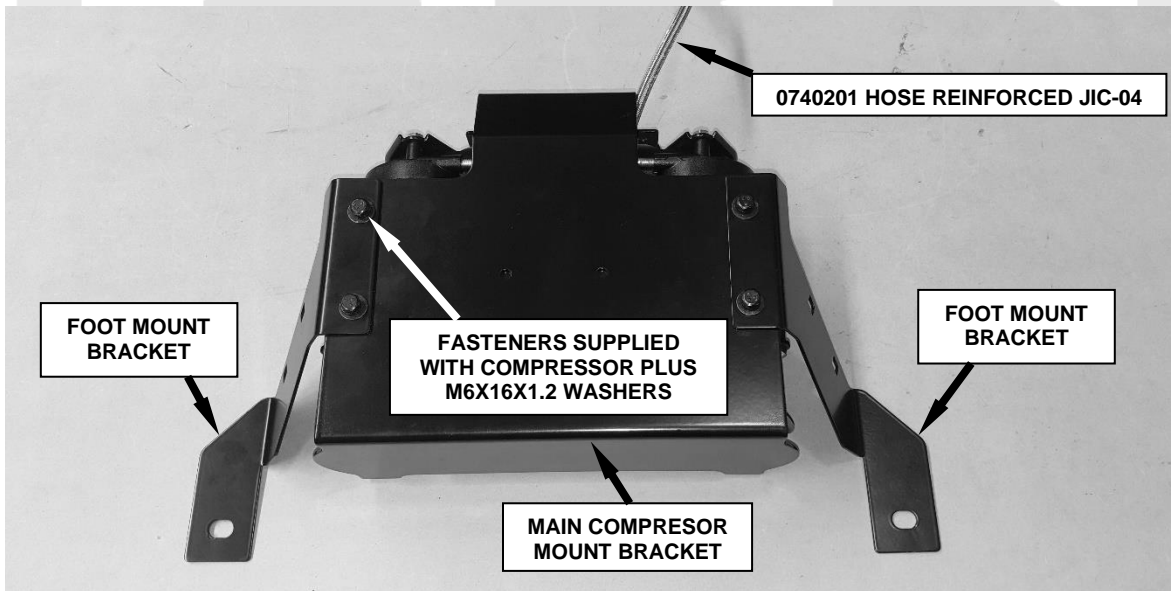

3 Assembly of Compressor to Main Bracket

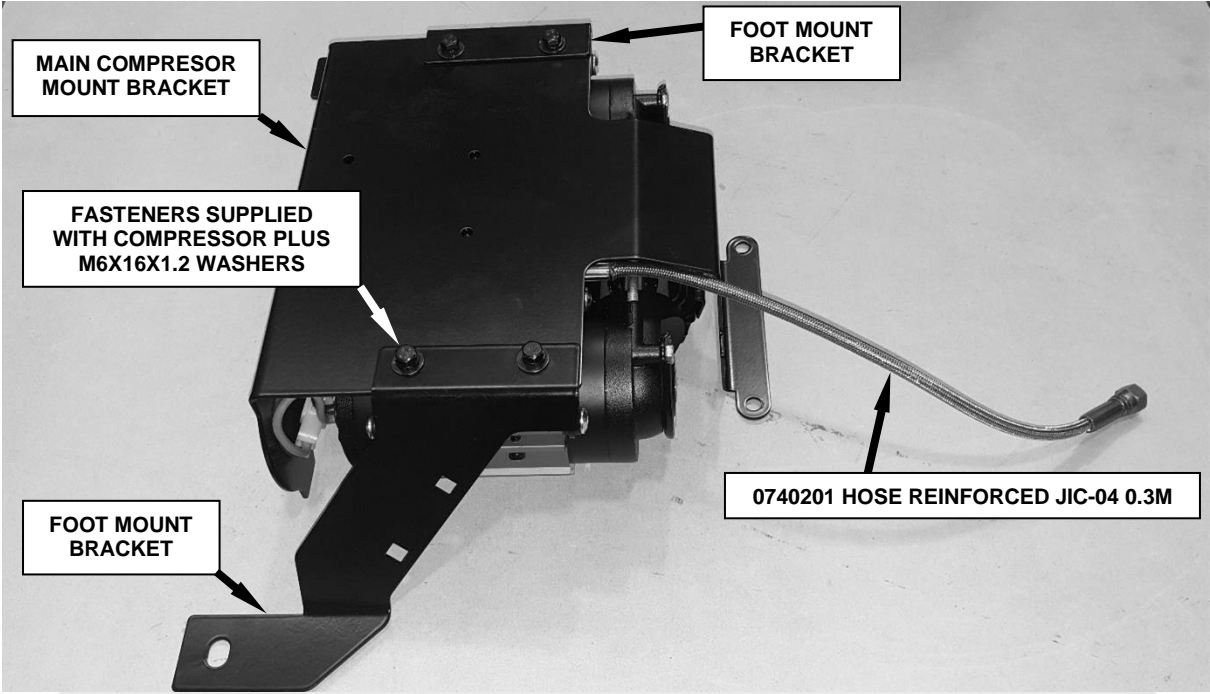

3 Assembly of Compressor to Main Bracket

3.2 Assembly of Switch and Quick Connect Coupling Plate

The switch panel plate can be configured to fit on either the Left or Right hand side of compressor bracket. Configuration is determined through the fitment of the compressor bracket assembly in vehicle. If the compressor bracket is fitted to RHS of vehicle configure switch panel for RHS and if fitted to LHS of vehicle configure switch panel for LHS as shown in images below.

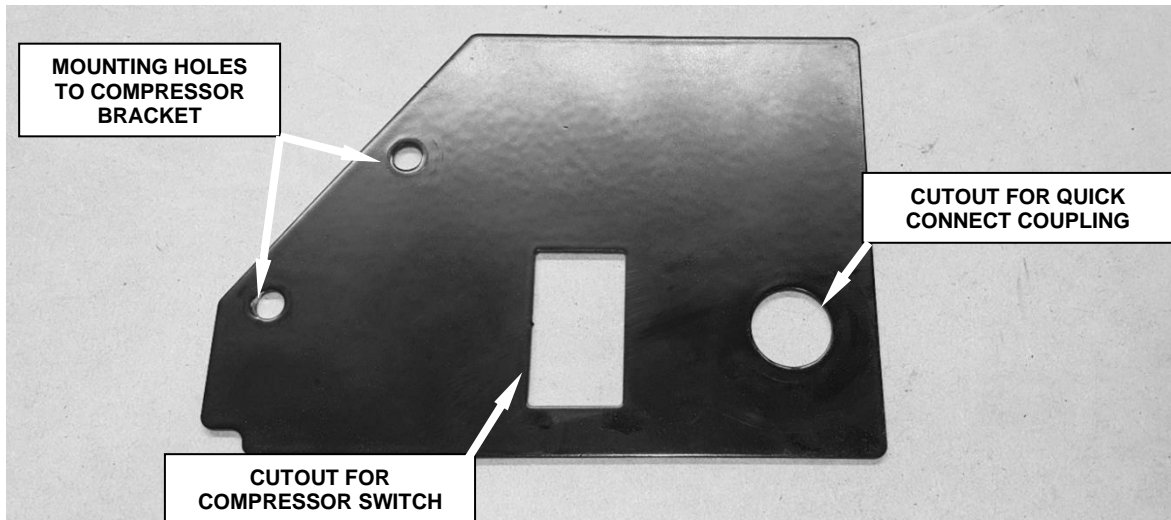

Switch plate configuration for Right Hand Side fitment



Switch plate configuration for Left hand Side fitment



3 Assembly of Compressor to Main Bracket

3.3 Configuration of the Air Locker Manifold kit

- Remove manifold from 171503 packaging
- Remove ¼ NPT plug and JIC-4 Adaptor from manifold

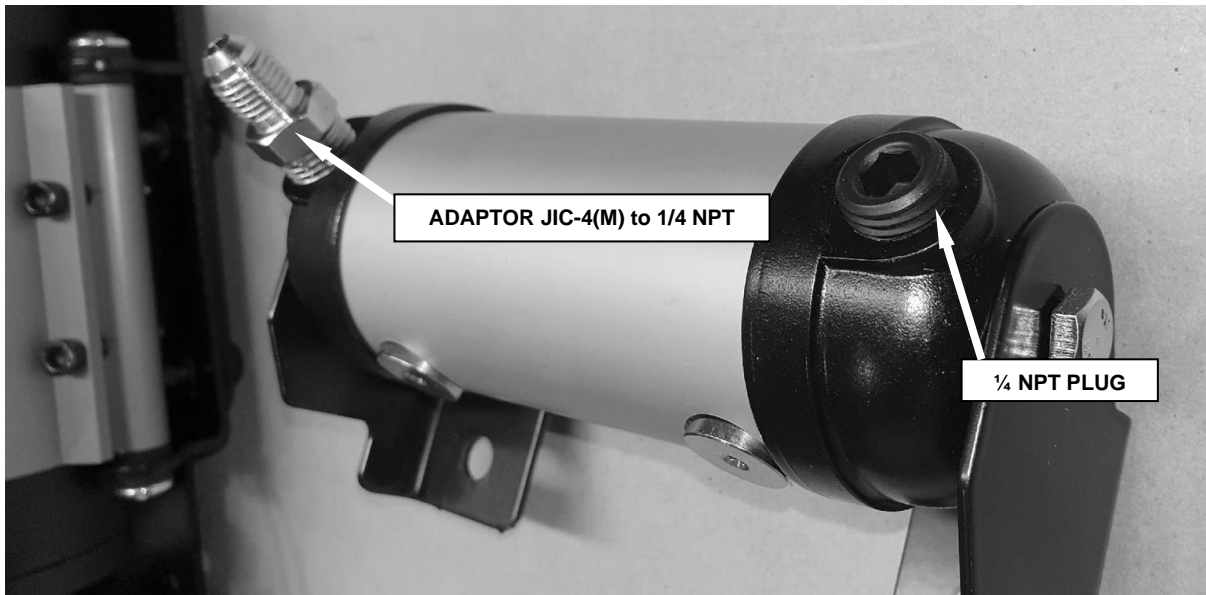

- Install 2 X ADAPTOR JIC-4(M) to 1/4 NPT adaptors to manifold and seal threads as shown. Use previously removed adaptor plus second adaptor found in Air Locker Manifold kit (use 14mm spanner)

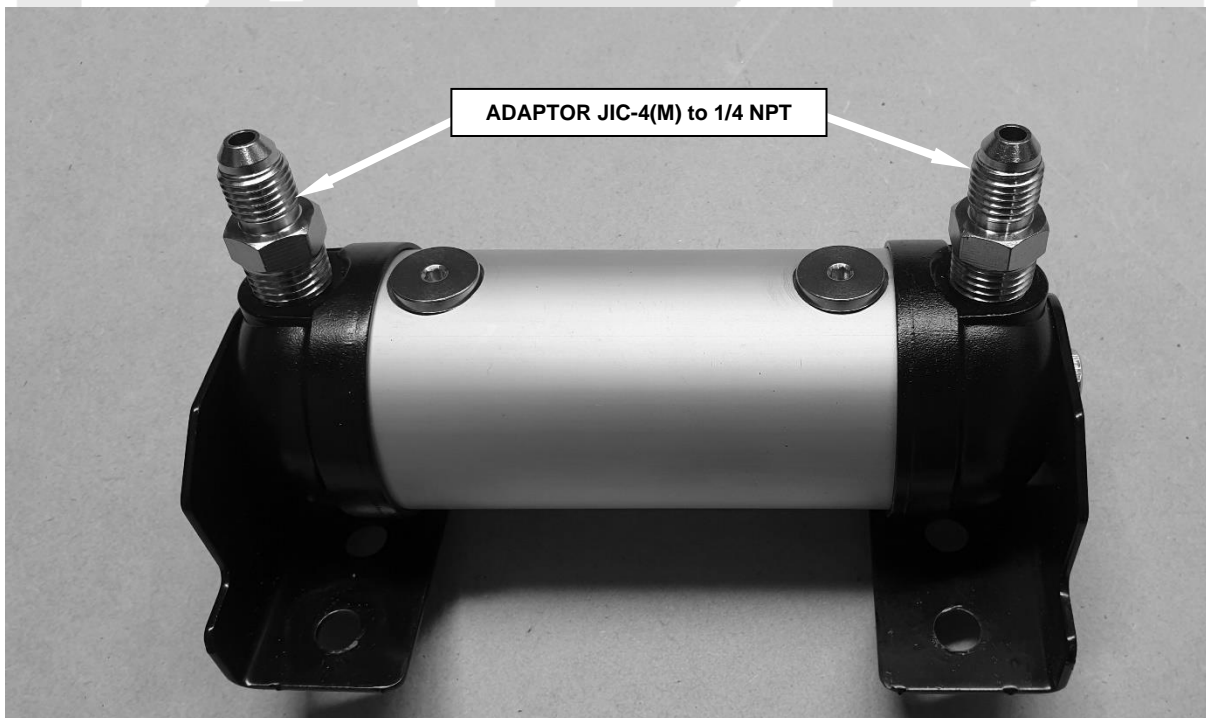

4 Installation of Compressor Bracket Assembly

4.1 Installation of Compressor Bracket Assembly

NOTE: The images below relate to the fitting of the compressor bracket to the RHS of the vehicle. When required instructions indicate when an LHS or RHS operation is performed

- Remove grommet from floor panel as shown below.

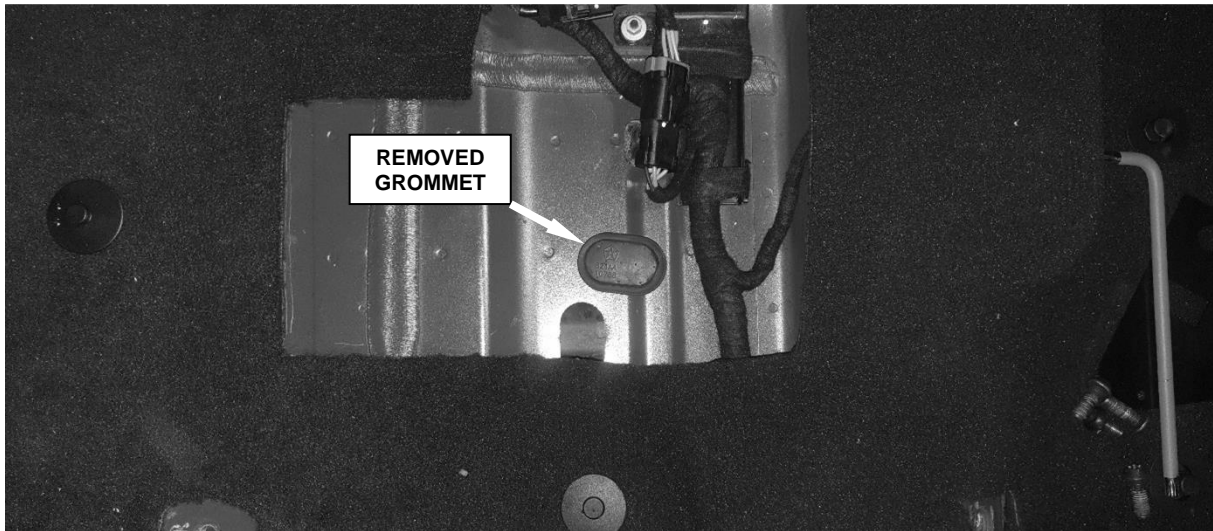

- Position the compressor bracket assembly as shown below
- Temporarily fix compressor bracket assembly in place. Use 2 of the seat retaining torx head fasteners to locate compressor mount bracket as shown below.

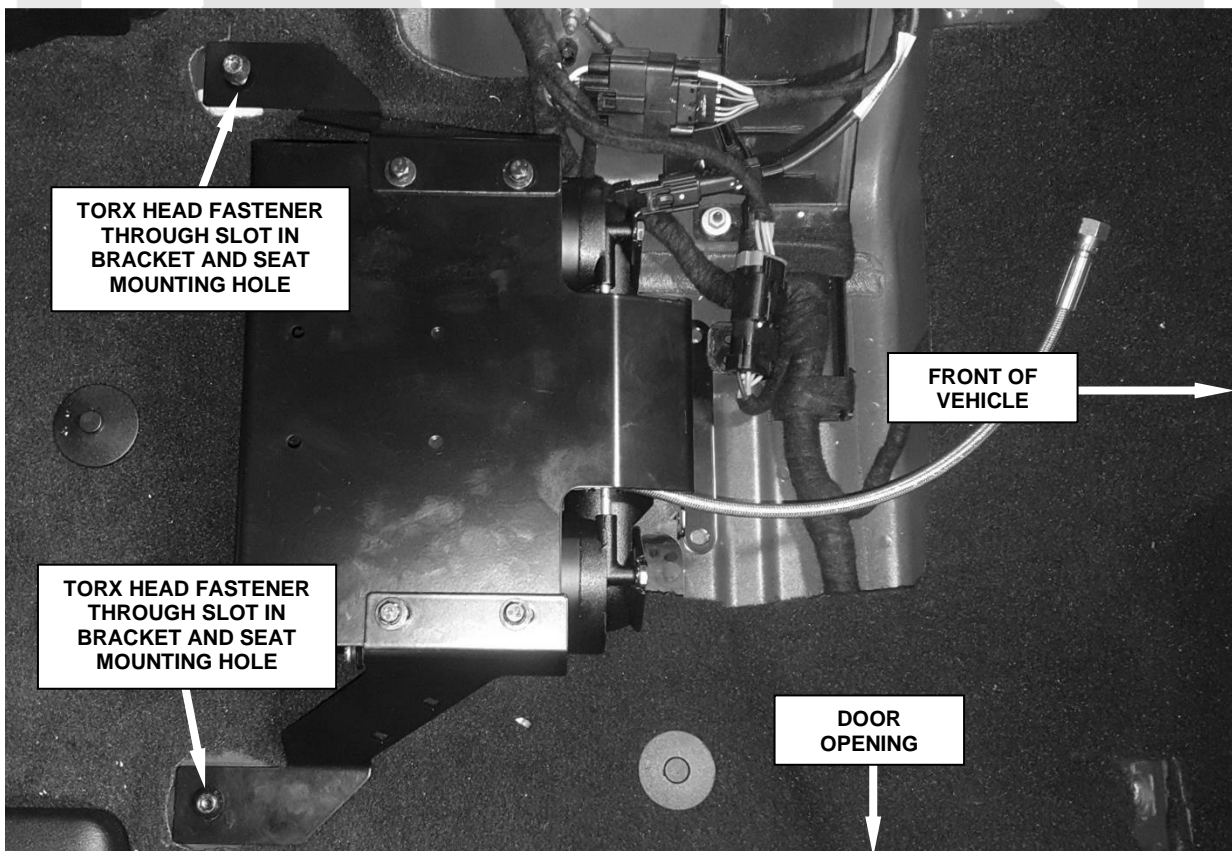

4 Installation of Compressor Bracket Assembly

Note: The compressor mount bracket is fixed to the floor panel using a M8 Fastener in one of the front mount holes. The hole which is used is dependent on the side of the vehicle in which the compressor mount bracket is placed.

- Identify the hole for fixing the compressor bracket to the floor panel. This is the hole which is the shortest distance to door opening. Image below indicates hole position when compressor mount bracket is fitted to RHS of vehicle.
- Check under floor panel through grommet opening to ensure there are no obstructions when hole is drilled.

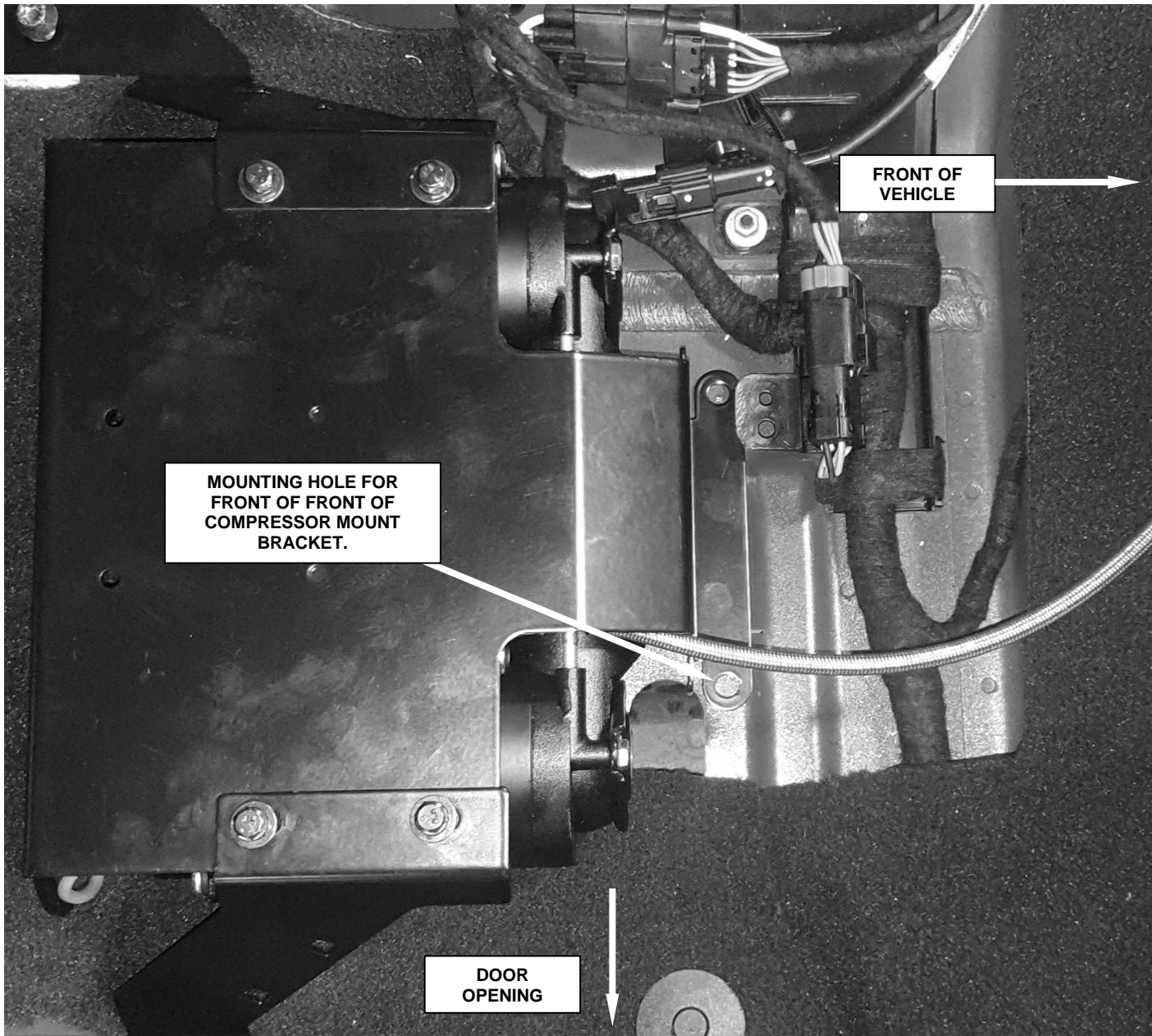

4 Installation of Compressor Bracket Assembly

- Using an 8.5mm drill wrap some tape around to provide a temporary depth stop. Place tape so it allows for a drill depth between 10–15mm.

Note: Care is need when drill front mounting hole. If fitting to the RHS of vehicle the is a danger of drilling in the fuel tank if hole is drilled without using a depth stop on drill.

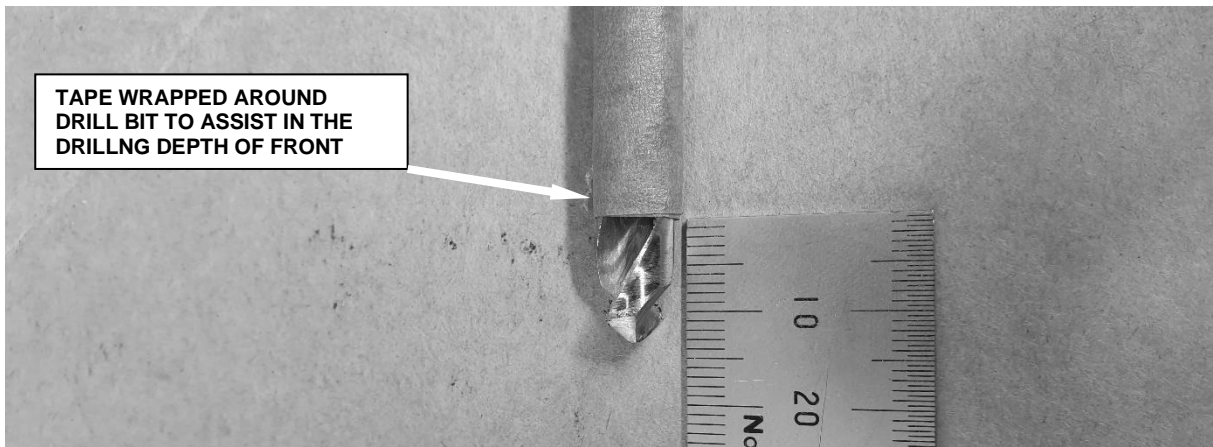

- Drill 8.5mm hole trough floor panel

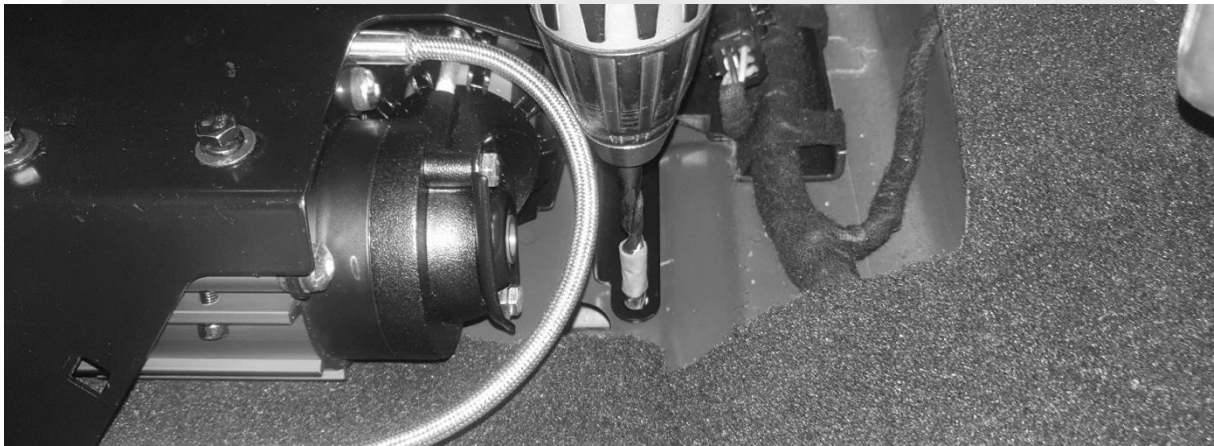

- Deburr drill holes to remove sharp edges and treat bare metal edges to prevent corrosion

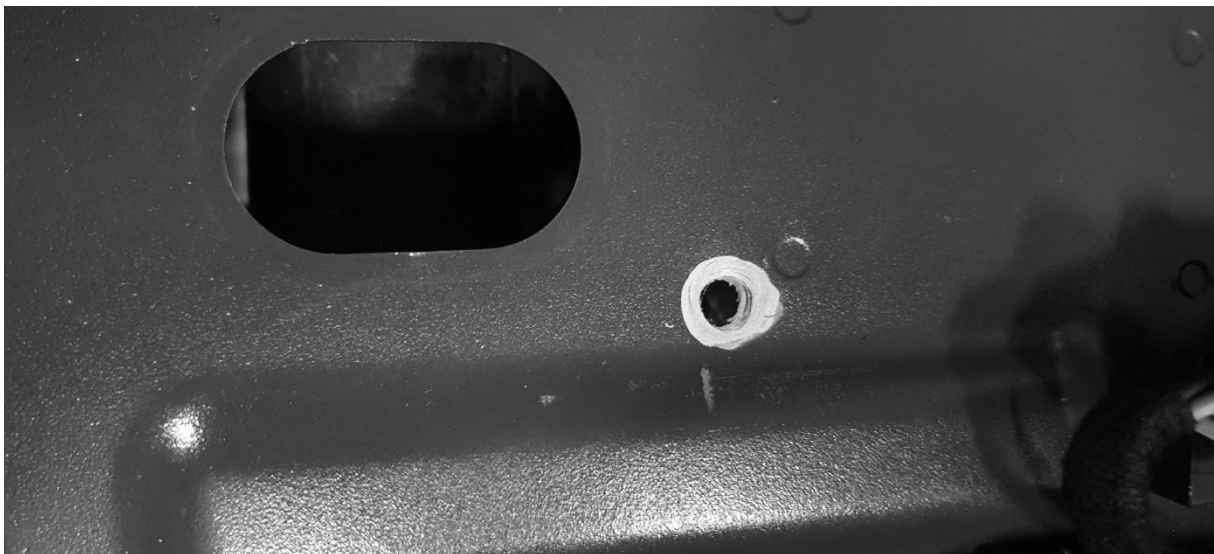

4 Installation of Compressor Bracket Assembly

- At this stage of the installation refer to the installation guide that came with the compressor for detailed instructions for wiring of the compressor prior to fixing compressor mount to the floor of vehicle.
- Place M8 flange nut into 13mm ring spanner as shown



- Place flange nut under floor panel with aid of ring spanner align with drilled hole and secure in place using M8X20 hex head bolt and M8 X 17 x 1.2 washer.
- Torque M8 fasteners to 25Nm [18 lbf.ft]

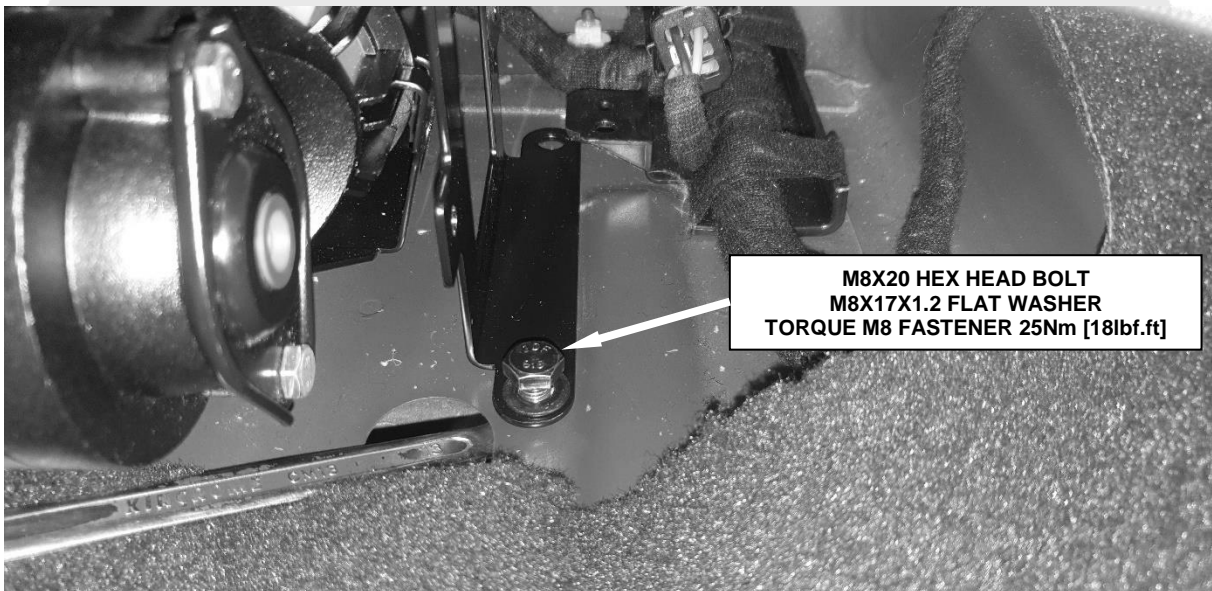

4 Installation of Compressor Bracket Assembly

- Attached manifold to compressor bracket as shown using the fasteners supplied with manifold kit
- Torque M6 fasteners to 9Nm [7lbf.ft]

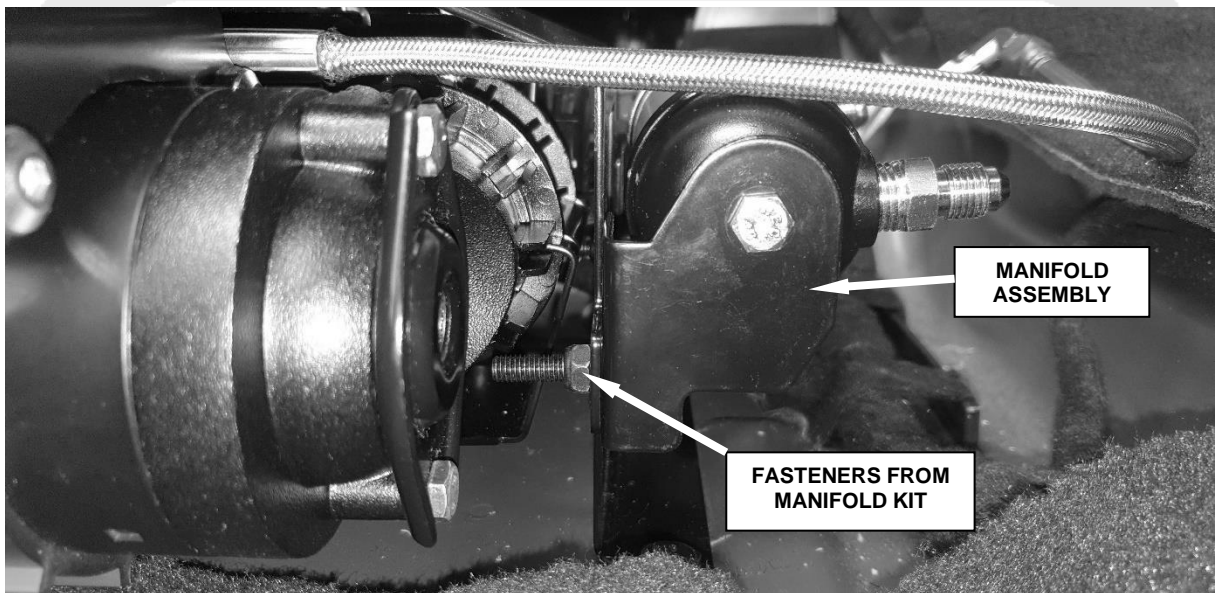

4 Installation of Compressor Bracket Assembly

- Connect the 0740201 hose reinforced JIC-04 0.3M from the compressor to the manifold as shown below.
- Tighten Elbow and hose fittings using 14mm spanner and 12mm spanner to retain elbow.

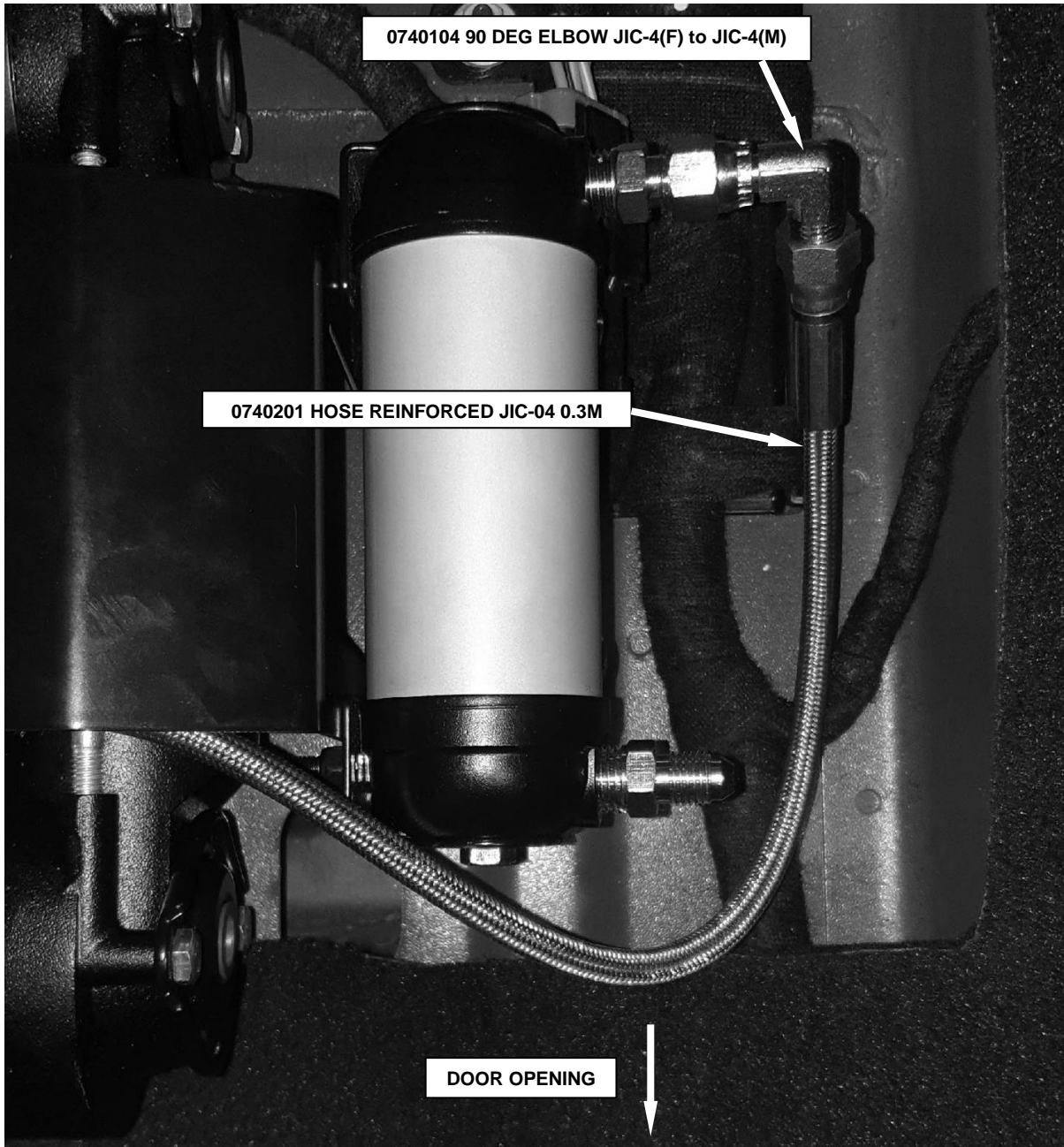

4 Installation of Compressor Bracket Assembly

- Install 2 X M6 cage nuts into compressor mount bracket as shown.

Note: Cage nuts are installed in the foot mount bracket which is closest to door opening. This allows for operation of the compressor switch and quick connect chuck when door is open. Photo shows installation to the RHS of vehicle.

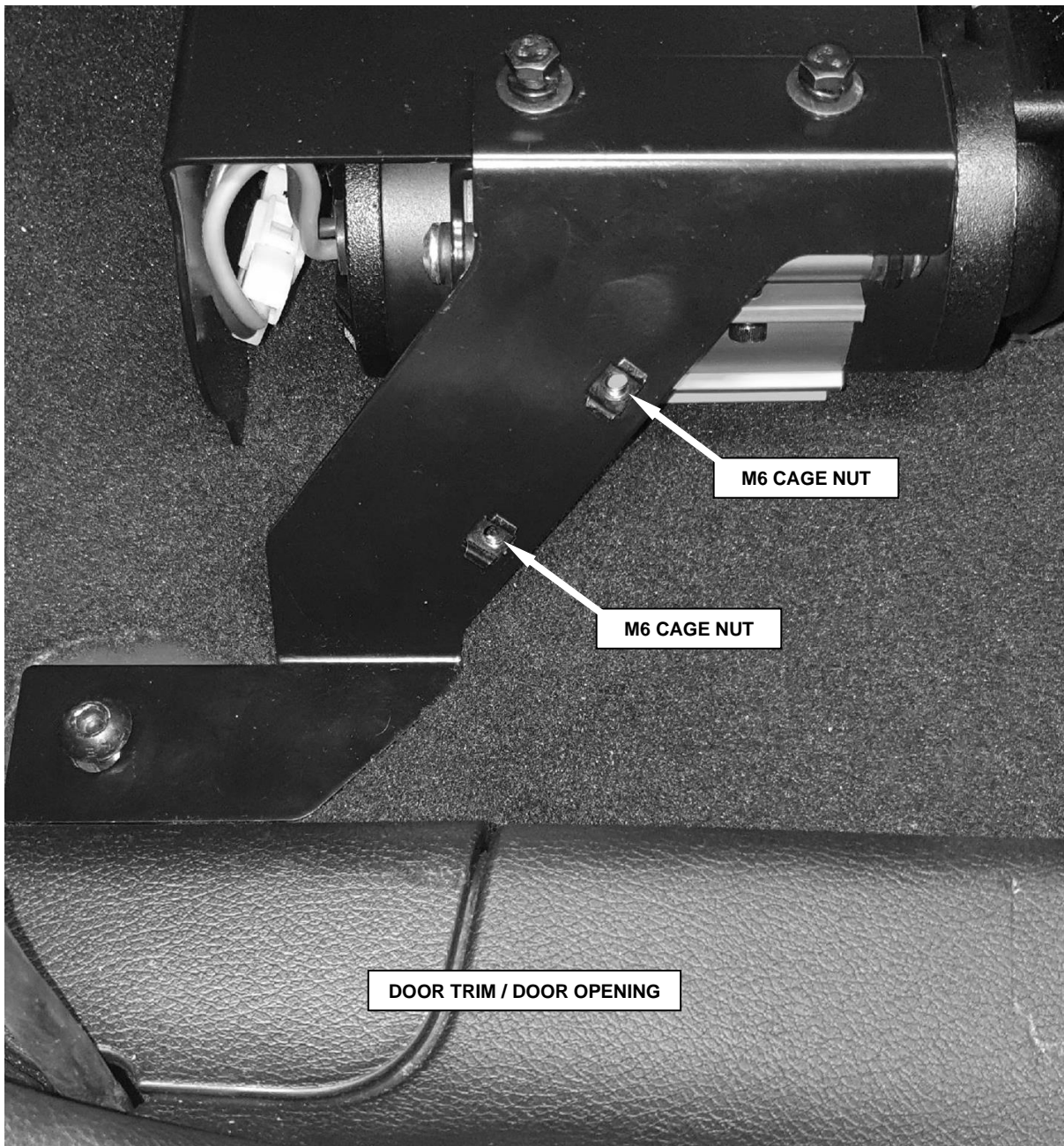

5 Installation of Air Tank

5.1 Installation of Air Tank

The image below shows the air tank bracket which attaches to the crossmember under vehicle.



- Mount air tank bracket to chassis as shown using the fasteners listed below.
- Do not fully tighten M8 bolts at this stage.

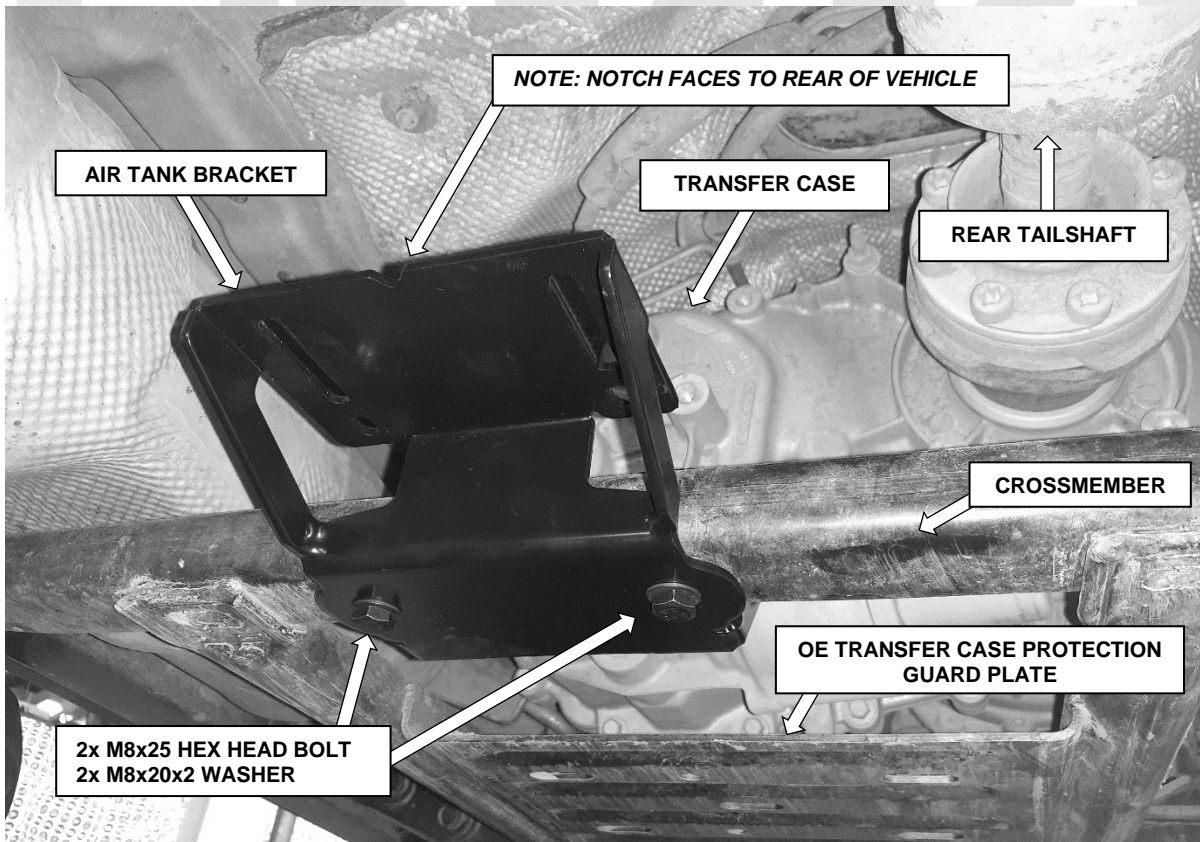

5 Installation of Air Tank

Installation of Air Tank on 3.6L Vehicle Models

- For Installation of Air Tank on 2L Vehicle Models go to **Page 29**.
- Place and mount air tank to the air tank bracket through the long slots on the bracket as shown, using the fasteners that came with the air tank kit plus 4x Flat Washers (M6X16X1.2) supplied with the compressor bracket kit. **Do not fully tighten bolts at this stage.**
- Once bolts are threaded into the tank fittings, slide the tank along the slots towards the rear of the vehicle, away from the vehicle transfer case.

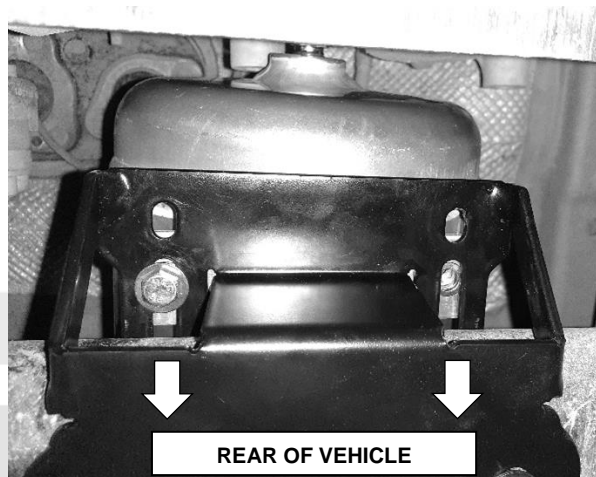
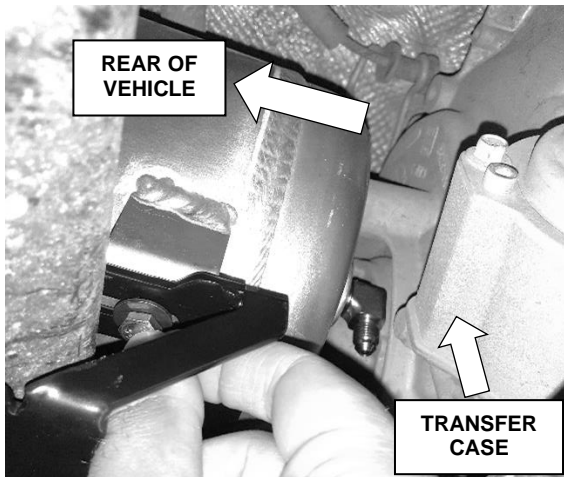

- Once the tank is positioned at the most rearward position on the bracket, tighten all bolts. A spanner will fit between the mounting crossbar and the bracket to allow access to the bolts.
- Torque M6 fasteners to 9Nm [7 lbf.ft]

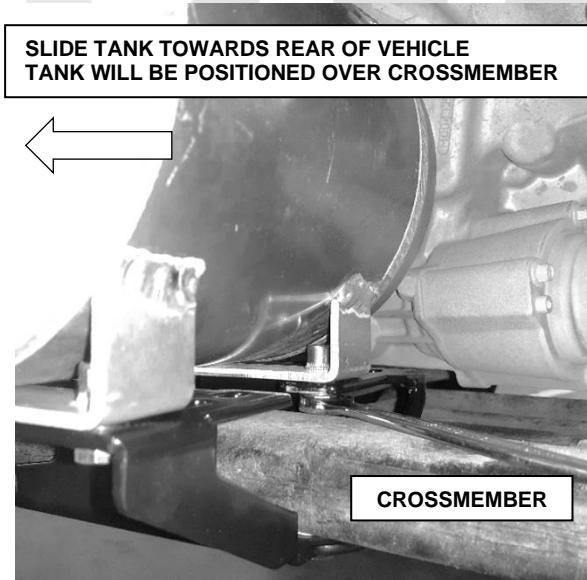

- Fully tighten all fasteners.
- Torque M8 fasteners to 25Nm [18 lbf.ft]
- Ensure air tank does not make contact with transfer case and other vehicle components.

5 Installation of Air Tank

Installation of Air Tank on 2L Vehicle Models

- Place and mount air tank to the air tank bracket through the short slots on the bracket, using the fasteners that came with the air tank kit plus 4x Flat Washers (M6X16X1.2) supplied with the compressor bracket kit.
- Fully tighten all bolts.
- Torque M6 fasteners to 9Nm [7 lbf.ft]
- Torque M8 fasteners to 25Nm [18 lbf.ft]
- Ensure air tank does not make contact with transfer case and other vehicle components.

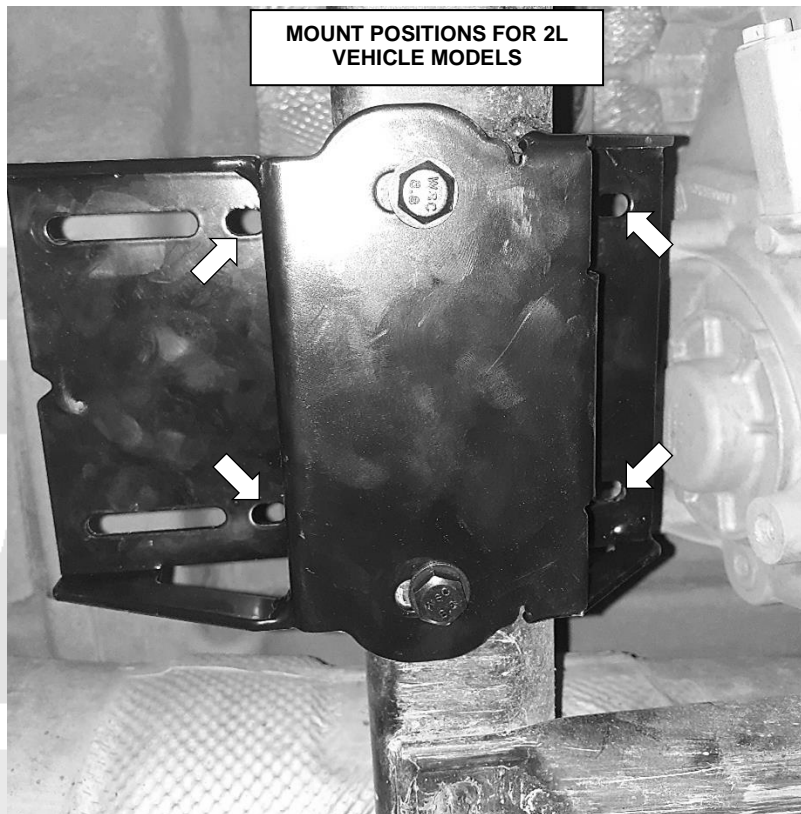

5 Installation of Air Tank

5.2 Connecting Hoses

The following section describes the installation of the hoses to connect the compressor to the remote mounted air tank when the compressor has been mounted to the RHS of vehicle. On a RHS fitment 2X 0740204 Hose Reinforced JIC-04 1.5M hoses are used. On a LHS fitment 2X 0740203 Hose Reinforced JIC-04 1.0M are used

- Connect one of the hoses (0740204 Hose Reinforced JIC-04 1.5M) directly to the quick connect coupling as shown.
- Connect the other hose, (0740204 Hose Reinforced JIC-04 1.5M) and a 0740104 90 DEG Elbow JIC-4 (F) to JIC-4 (M) to the free port on the manifold

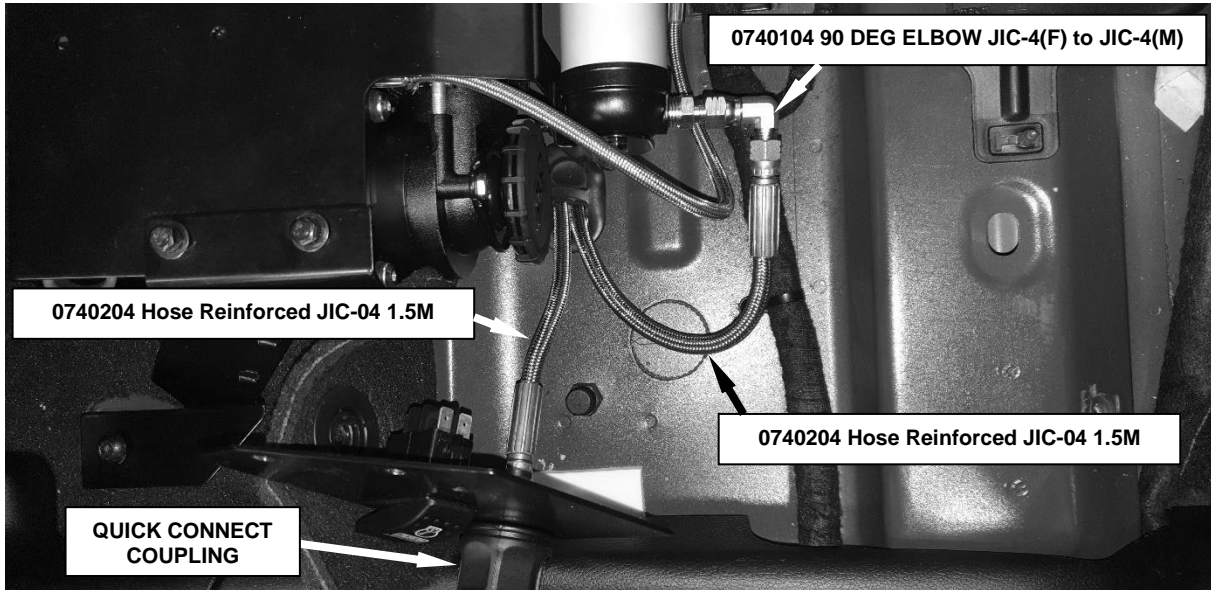

- Cut a "D" section out of floor grommet to allow both hoses to be passed through as shown below
- Pass both hoses through the floor to underside of vehicle



5 Installation of Air Tank

- Secure switch and quick coupling plate assembly using fasteners as shown below

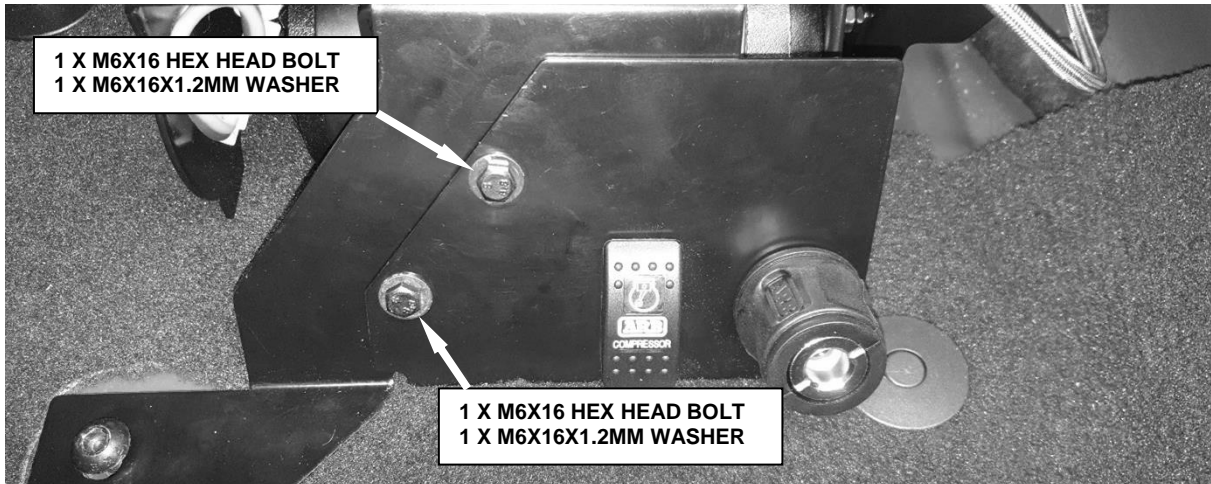

- Working underneath vehicle connect one of the hoses, (0740204 Hose Reinforced JIC-04 1.5M) using a 0740104 90 DEG Elbow JIC-4 (F) to JIC-4 (M) to the rear facing port of the air tank (this is the face of the tank towards to the rear of the vehicle)

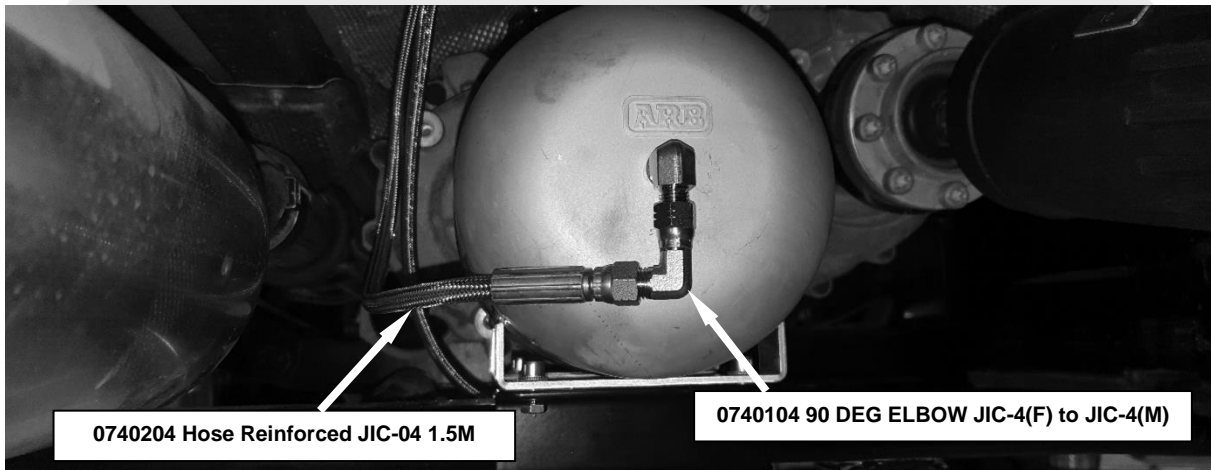

- Connect the other hose (0740204 Hose Reinforced JIC-04 1.5M) directly as shown

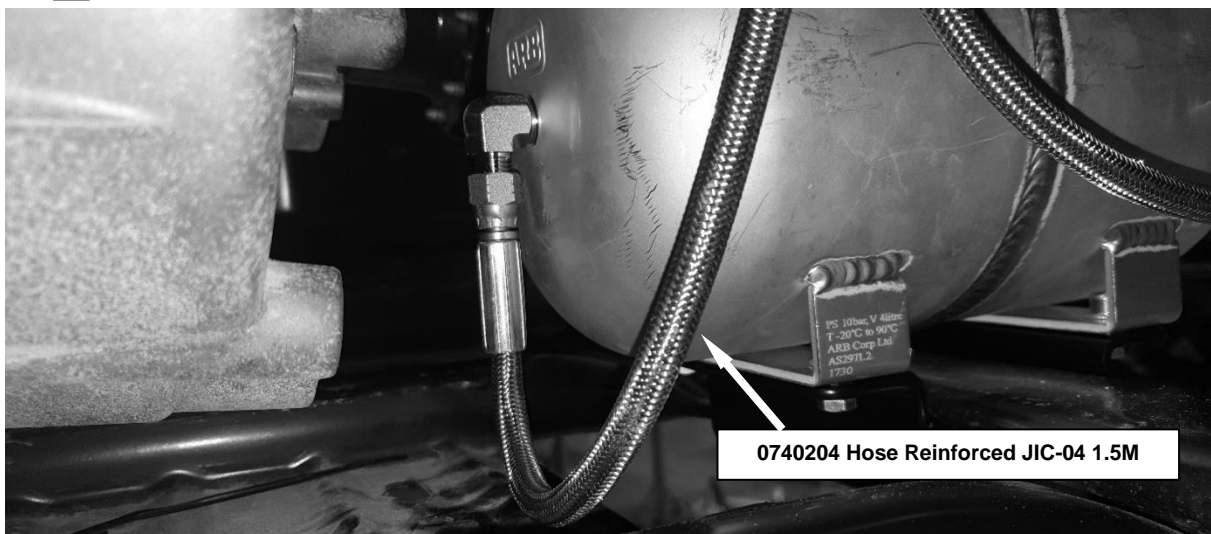

5 Installation of Air Tank

- Remove the two plastic heat shield retaining washers and replace with one 19mm P-Clip in each location to retain and route both (0740204 Hose Reinforced JIC-04 1.5M) hoses as shown.
- Secure the P-Clips in place with one M6X16x1.2 Washer and a M6 Nyloc Nut.

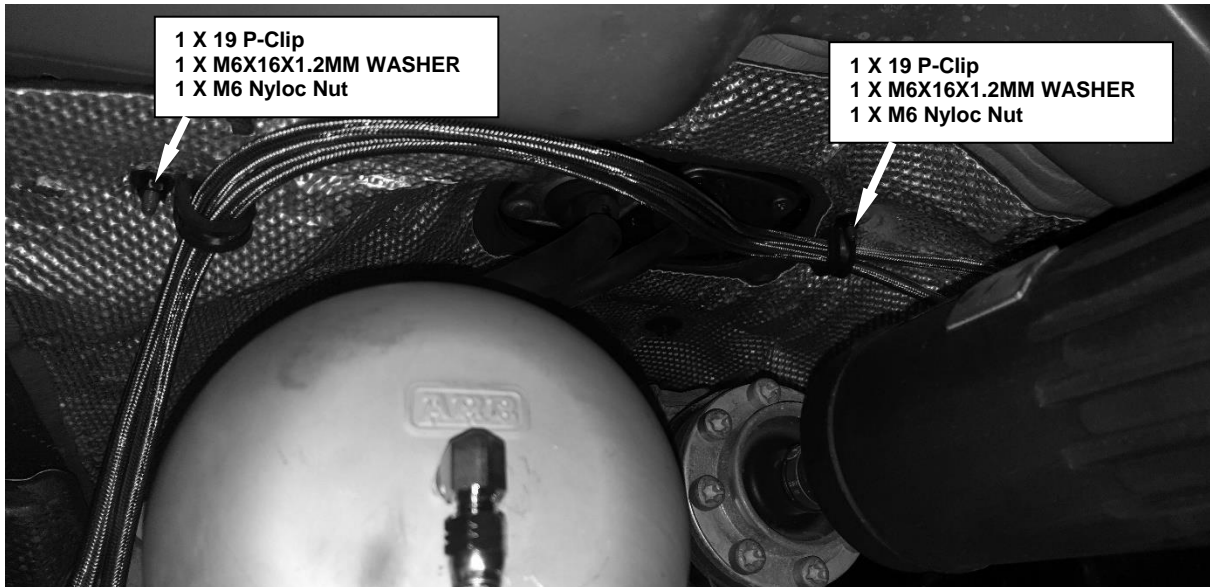

- Tighten all hose fittings using 14mm spanner and 12mm spanner to retain elbows

6 Completing Installation

6.1 Seat installation

- Refit seat back into vehicle and ensure all electrical connections that were disconnected for the removal of the seat are re-connected.

6.2 Post-Installation Check List

Now that the compressor installation has been completed, ARB recommends that you take the time to complete the following check list just to ensure that you haven't missed any of the vital steps.

- The air system has been leak tested.
- The air filter position will not be exposed to moisture, dust or dirt.
- All air lines and wiring have been securely cable tied to resist snagging.
- Switch(es) have been securely mounted within operator reach, yet well away from danger of accidental engagement.
- Switch(es) function properly and illuminate to indicate activation.

For warranty and service purposes, please fill in the following fields and supply a copy to the customer (if applicable).

ARB PRODUCT MODEL NUMBER: _____

SERIAL No: _____

POINT OF SALE (NAME/LOCATION): _____

DATE OF PURCHASE: _____

INSTALLATION PERFORMED BY: _____

DATE OF INSTALLATION: _____

VEHICLE MAKE: _____

VEHICLE MODEL: _____

VEHICLE YEAR OF MANUFACTURE: _____